

## THIN CLIENT IN MASSIVE RLS WITH CLOUD APPLICATION

Pavel BEŇO

### Abstract

*Many organizations, both large and small, are investigating the potential of thin client architectures for their companies. In general, a thin client is the one which does not have any local storage and we are using this because of their many advantages. Few year ago, we build our own virtualized cloud for REMLABNET and we still are taking benefits of this decision. This item handels with using Cloud computing platform for providing Remote laboratories. This work show, how it is possible to save money if we use centralized system for more consumers. Every consumer can use access to centralized portal in the Cloud computing from Consortium REMLABNET. Every item is focused on enviroments of universities, where this cloud is existing and this is what we want use for remote labs. This is item from practice knowledge and experiences about system function and managing virtual platform and next construction this proposal.*

### Keywords

*cloud, computing, virtual, platform, datacenter, network, availability, remote labs, thin client*

## I. INTRODUCTION

IT departments in companies and also in universities are permanently under pressure to provide high quality services with reduced budget. On the other side, costs of energy for datacenters (DTCs) running and cooling call for radical changes in their organization compared to classic datacenters. Few years ago, we were using a prevailing standard in the decentralization and fractionating of services to several physical devices. This approach is nowadays under severe changes in direction to consolidation of datacenters denoted under cumulative term of virtualization. Virtualization has to offer decrease in energy consumption and increase in system performance without compromise on security of DTCs [01].

The last two decades has seen the rise of the DTC computing practically in every application domain. The move to DTC has been powered by two separate trends. In parallel, functionality and data usually associated with personal computing have moved into the DTC; users continuously interact with remote sites while using local computers, while running intrinsically online applications, such as email, chat, or manipulating data, traditionally these are stored locally, such as documents, spreadsheets, videos and photos. In effect, modern architecture is converging towards cloud computing, a paradigm where the whole user activity is funneled into the large DTC via high-speed networks. Simply speaking, cloud computing is a set of computers, services or infrastructure. Delivering services are ment to reduce the work of consumers every day, as well as service providers and IT specialists. Cloud computing allows more access services as it reduces infrastructure delivery time from weeks to hours and it offers reimbursement for provided sources and services only [02].

Main idea of our work and this paper, is for consumers to use new methods on how to provide remote laboratories. On the Figure 1, we can see primary idea of this system. On the left side, we can see individual remote laboratories, experiments, with HW and SW equipment, connected to our virtualized cloud. Core of our cloud is management system for

monitoring, diagnosing and administrating remote experiments and users, or our consumers. This management system is named Remote Laboratory Management System (RLMS) and it is consisted of few modules. For example: diagnostic server, data warehouse and content management system (with schedule and calendar, communication server,...).

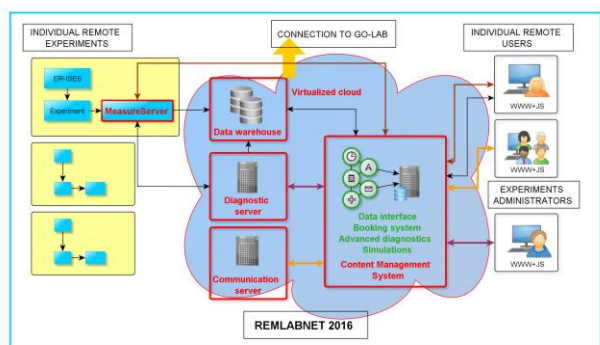

Figure 1 – block diagram of REMLABNET

## II. CLOUD COMPUTING CONCEPT

Of course, our work is primary oriented for remote laboratories, but our idea is to provide remote laboratories like cloud computing service. We were first in the world, who provided remote laboratories via this technology. A new concept of our cloud computing is figured on the Figure 2, where we can see all interesting parts of this idea.

First, we can see main parts of cloud computing. Each cloud is based on three primary services for use [03]:

**IaaS** – Infrastructure as a service is a standard service for providing all infrastructures;

**PaaS** – Platform as a service is a standard service for providing VMs with operating systems;

**SaaS** – Software as a service is a standard service for providing SW features for consumers;

Virtualized DTC contains physical and virtual servers, which serve a variety of services including web services, file services etc. The advantages of DTC are enabling application isolation from malicious or greedy applications cannot impact other applications co-located on the same physical server. Perhaps the biggest advantage of employing virtualization, is the ability to flexibly remaps physical resources to virtual servers in order to handle workload dynamics.

Server resources in a data center are multiplexed across multiple applications and each server runs one or more applications. These applications are usually business critical applications with Quality-of-Service (QoS) requirements. The resource allocation needs to not only guarantee that a virtual container always has enough resources to meet its application's performance goals, but also prevent over provisioning in order to reduce cost and allow the concurrent hosting of more applications.

Our other aims are: To construct really stable and dynamically expandable Cloud computing for using remote laboratories. To create VMs and linkage for all parts in cloud, create communication links, virtual network for cloud computing inside, and all needed parts for Cloud computing concept. The goal of our work is new and acute topic of providing a new service for the consumers - completely functioning "Remote laboratory as a service" (RLaaS) [04].

It is very interesting for all consumers of the Remote laboratories, because they can find this cloud concept and every remote laboratories. We created Consortium named REMLABNET

and this is consortium of the three universities: Trnava University in Trnava (Slovakia), Tomas Bata University in Zlin (Czech republic) and Charles University in Prague (Czech republic). REMLABNET portal is on domain name or web site [www.remlabnet.eu](http://www.remlabnet.eu) [05].

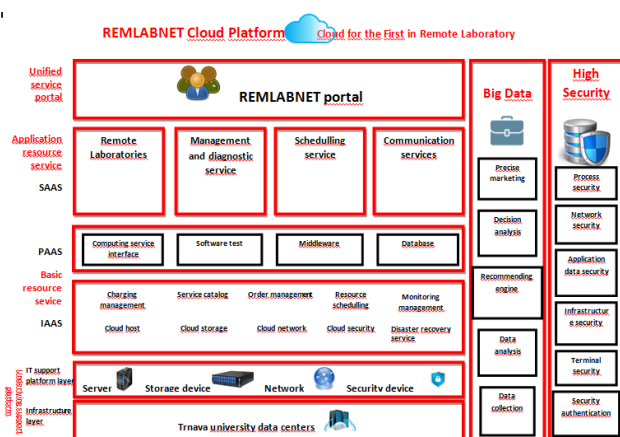

Figure 2 – Cloud computing concept in our Remote laboratory area

### III. THIN CLIENT IN RLS

#### CONCLUSIONS

Our idea of use Cloud computing was attested and discussed with experts in this research part. The way of our work is good and have a big progress. We can provide new service, Remote laboratory as a Service (RLaaS) in our cloud system and we are first to use thin client to communication between main experiment and virtual cloud. Our consumers are primary teachers, students and brainpower of the universities and high schools, but access is possible for all consumers via Internet. This show, how the university network is very overcast for communicaton and traffic. This claim, that network must be without failure and latency. And be secured too for management and research data protection. Security on the network is very important part, but it is without frame of this paper.

In this paper we showed our idea of construct Cloud computing system with important parts like using thin client. Our work is oriented to save money in education and research, if everyone builds their own Remote laboratories. We have connected many laboratories from Zlin University, Trnava University, Charles University and other in the world. Our work is in simple terms „Bring Technology to Service!“.

#### ACKNOWLEDGEMENT

The paper was published thanks to the University of Trnava, where the virtualized cloud is running.

#### REFERENCES

- [01] BENO, P., SCHAUER, F., JASEK, R.: *Security and risks in Cloud computing for the remote laboratories*. Zilina: ICTIC 2013. ISBN 978-80-554-0648-0, ISSN 1339-231X, pg. 333
- [02] BEŇO, P., KURTHA, T.: *Cloud computing, This is it!* Bratislava, VMWare conference + Zutom 2012
- [03] BEŇO, P., SCHAUER, F., VLCEK, K.: *University network with Remlabnet and communication among individual datacenters*. Varna, Bulgaria: IEEE Computer Society's Conference Publishing Services, 2014. ISBN 978-1-61804-246-0, pg. 240

- [04] SCHAUER, F., et al.: *REMLABNET - open remote laboratory management system for e-experiments*", REV 2014, Porto University, 26-28 February 2014
- [05] BEŇO, P.: *Neural Networks for Security Enhancement in Cloud Computing*. Žilina – Slovakia, ICTIC 2014, ISBN 978-80-554-0865-1, ISSN 1339-231X, pg. 305
- [06] CartouChe coordination, Cartography for Swiss Higher education, Zurich, 26.1.2012, [http://www.e-cartouche.ch/content\\_reg/cartouche/formats/en/html/Client\\_learningObject2.html](http://www.e-cartouche.ch/content_reg/cartouche/formats/en/html/Client_learningObject2.html)
- [07] Schauer, Ozvoldova: *Slovak e-laboratory of Remote Interactive Experiments for Teaching of Natural Sciences*, International Conferences on Emerging eLearning Technologies an Applications, ICETA 2007

#### **AUTHORS**

**Pavel Beňo** is currently working towards the Ph.D. degree at the Tomas Bata University in Zlín, Faculty of Applied Informatics, Czech Republic, in the field of remote laboratories. He is a research assistant and creator of the cloud computing technology for university and REMLABNET purposes. He is also expert in network security and forensic analyse in computer crime. He is the author of eight publications in the field of informatics and security.

*Recenzent: Ing. Eva Oláhová, PhD., Slovenská poľnohospodárska univerzita v Nitre*